

IEEE DySPAN 2010, Singapore

TV White Space Video Streaming Demo

Ser Wah Oh, Yonghong Zeng, Weiqiang Zhang,
Syed Naveen A. A., and Francois Chin

*Institute for Infocomm Research (I²R)
A*STAR*

Jun 7, 10

I²R Confidential



Goals and Architecture

- Goals
 - Testing spectrum sensing in real-world environment
 - Showcasing opportunistic utilization of unoccupied spectrum for communication
- Architecture

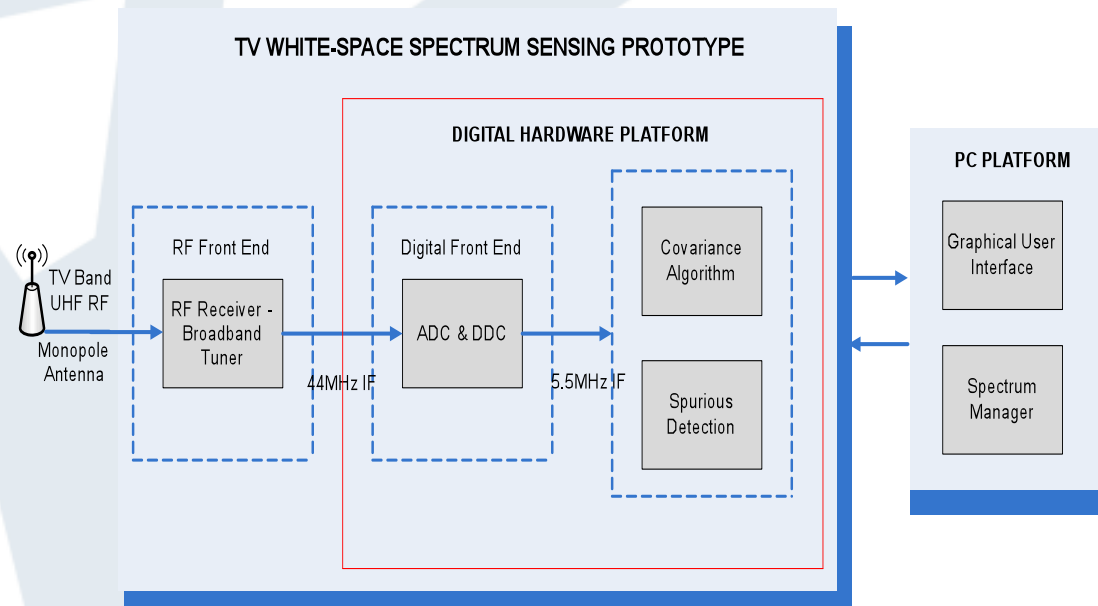

Demo 1

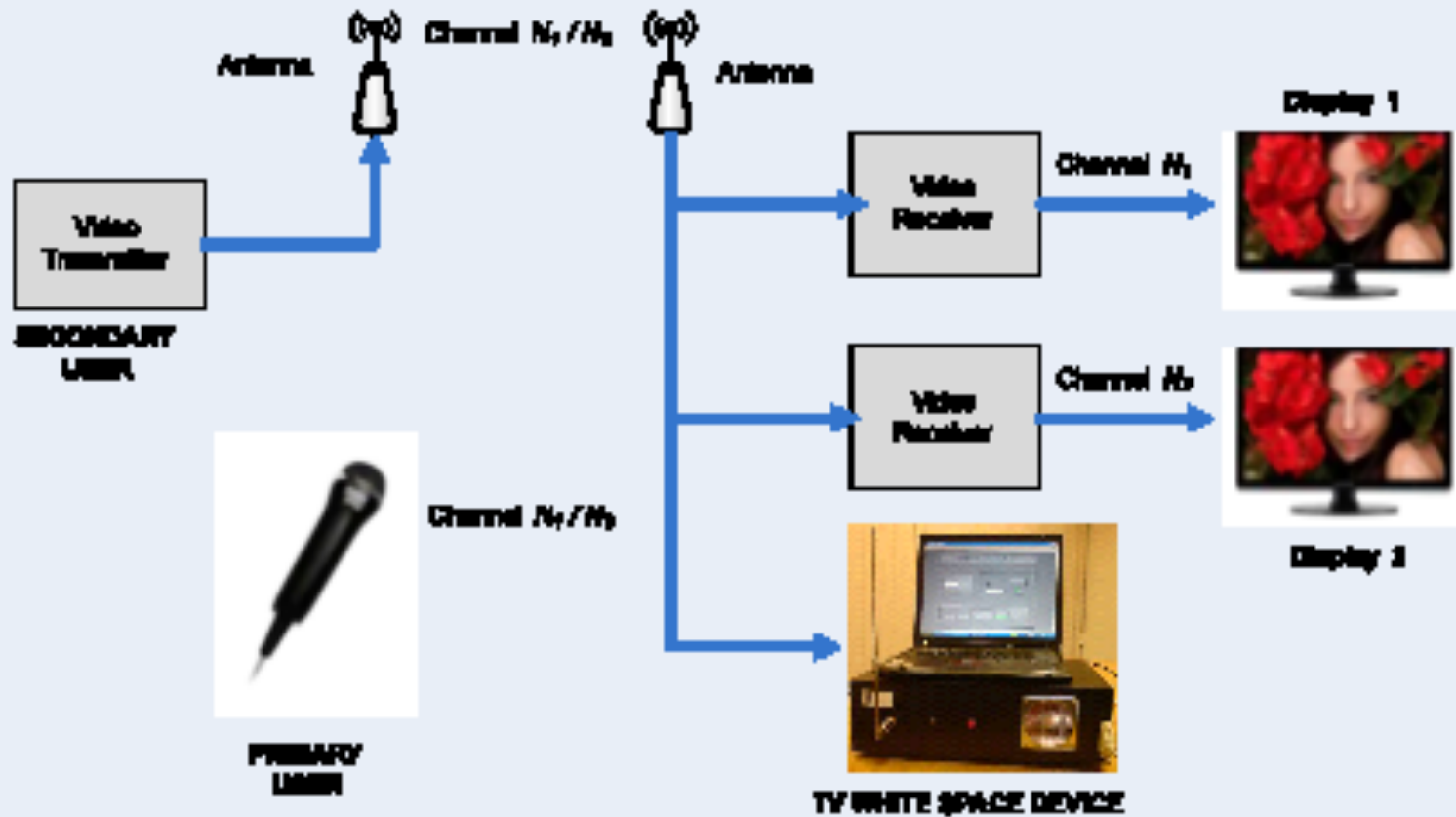

Demo 2

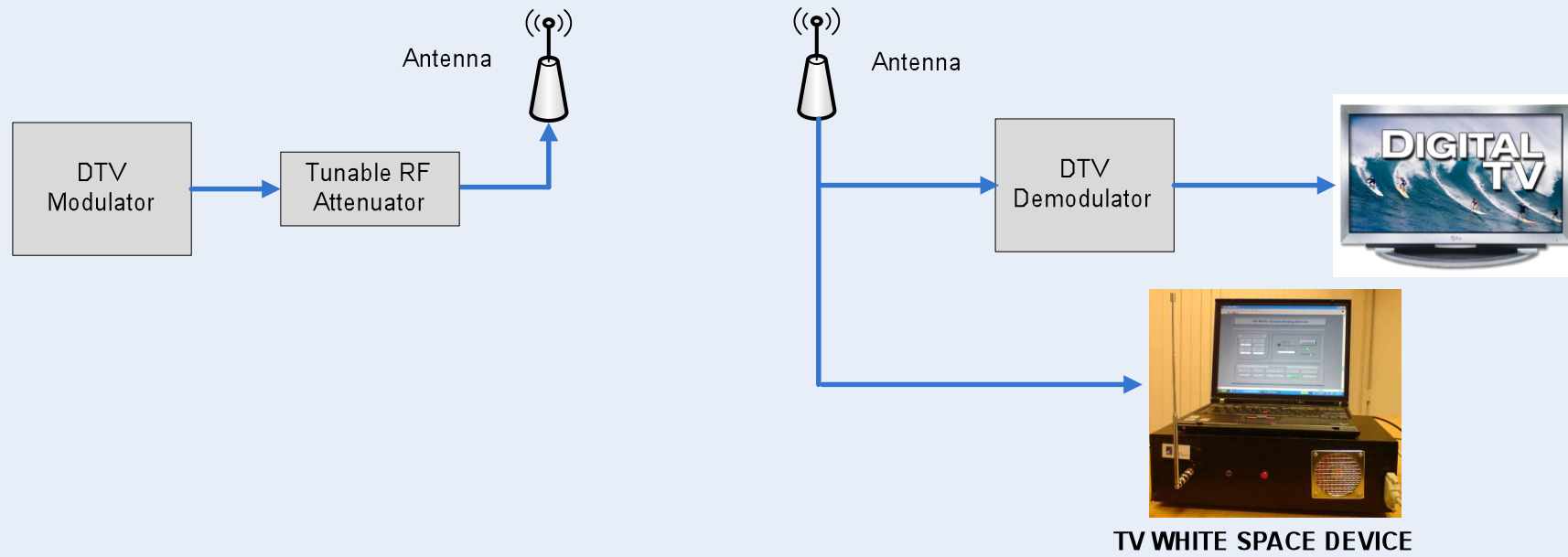

Frequency: 512 – 698 MHz
Bandwidth: 6 MHz