



# Demonstration of Sequence Detection Algorithms for Dynamic Spectrum Access Networks

Zhanwei Sun, Glenn J. Bradford and J. Nicholas Laneman  
Department of Electrical Engineering,  
University of Notre Dame, USA  
E-mail: {zsun2, gbradfor, jnl}@nd.edu

# Sequence Detection Algorithms for Dynamic Spectrum Access Networks

- Energy Detection does not consider the PU's channel access pattern.
- Sequence Detection
  - Based upon hidden Markov model, integrating memory into spectrum sensing
  - Different cost factors for missed detections and false alarms
  - Minimizing detection risk

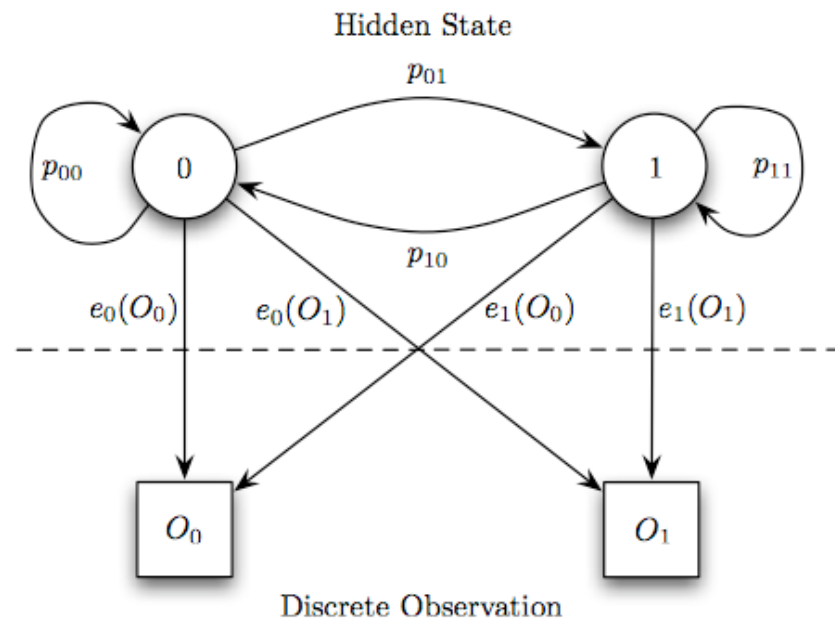

# Network Setup

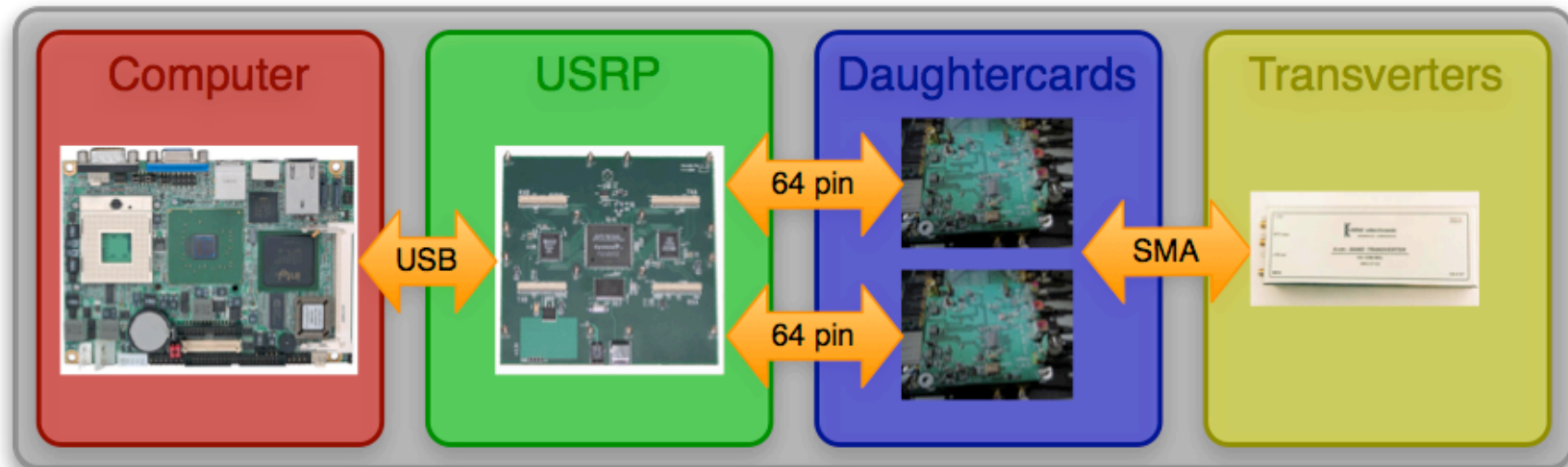

- A PU pair and a SU pair operate at the same frequency band, with video streaming for each user
- Primary transmitter accesses the channel in a Markov chain
- Secondary transmitter accesses the channel opportunistically on detecting spectrum hole

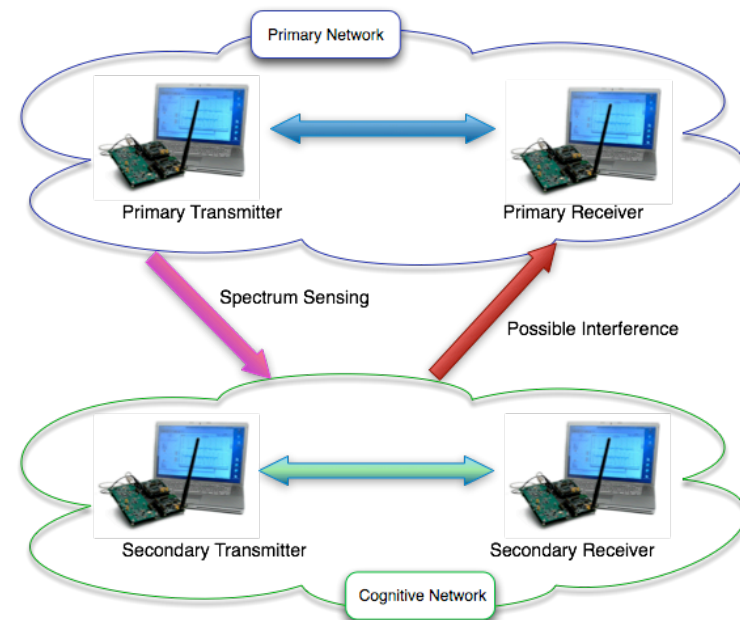

# Demonstration

