



# Ciena's Intelligent Optical Network Deployment and Directions

Lyndon Y. Ong

Snr. Technology Director, Ciena

Chair, OIF Technical Committee

[lyong@ciena.com](mailto:lyong@ciena.com)

Session 102

December 2, 2009

# Ciena at a glance

Founded / IPO	1992 / 1997
Headquartered	Maryland, USA
NASDAQ Listing	CIEN
FY'08 Revenue	\$902M
Employees Worldwide	2,110 <i>(as of 7/31/2009)</i>
Development Centers	CA; GA; MD; WA; Ottawa; Gurgaon, India
Customers Worldwide	600+
Service and Support	NA, EMEA, LA, AP

Optical Service Delivery Elements

Carrier Ethernet Service Delivery Elements

Unified Network & Service Management Software

Services

- ◆ First commercialized DWDM technology
- ◆ First intelligent optical switch
- ◆ World leader in optical control plane
- ◆ First and only programmable optical line cards
- ◆ Leaders in packet + optical networks
- ◆ Driving work on 100G and beyond

# Basic Philosophy

## Ciena's Core Infrastructure Philosophy:

- **Provide an automated pool of scalable, programmable bandwidth**
  - Lower the cost of the backbone network for IP transport
  - Deliver differentiated Carrier Ethernet and optical services

## Network Evolution

- Current networks use standalone TDM and limited packet switching over SONET/SDH rings and fixed DWDM transport
- Ciena's solution integrates Packet Transport, SONET/SDH, OTN and photonic mesh switching
- **Ciena utilizes advanced multi-layer Control Plane to optimize network operations, survivability and new service opportunities**

**Automated, not complicated**

# Optical Control Plane: the Good News

## Successfully Automates

- **Discovery and network inventory**
  - The network is the database
- **Service provisioning**
  - One touch end-to-end automated provisioning
- **Service recovery upon failure**
  - Sub-second mesh restoration with multiple CoS

## Status

- **Deployed in many of the world's largest Tier 1 carrier networks**
- **Well-developed Control Plane Standards**
  - ITU-T Recommendations G.8080, G.7712, G.7713, G.7715
  - IETF RFCs 3471/3, 4202/3
  - OIF UNI/E-NNI 1.0 and 2.0 Implementation Agreements



# Ciena's FastMesh™ intelligent optical control plane



Development timeline



Automated provisioning with end-to-end least-cost diverse routes

Multiple, dynamic path choices for >99.9999% ultra-survivability

→ Shared protection gain: 30-40% fewer wavelengths

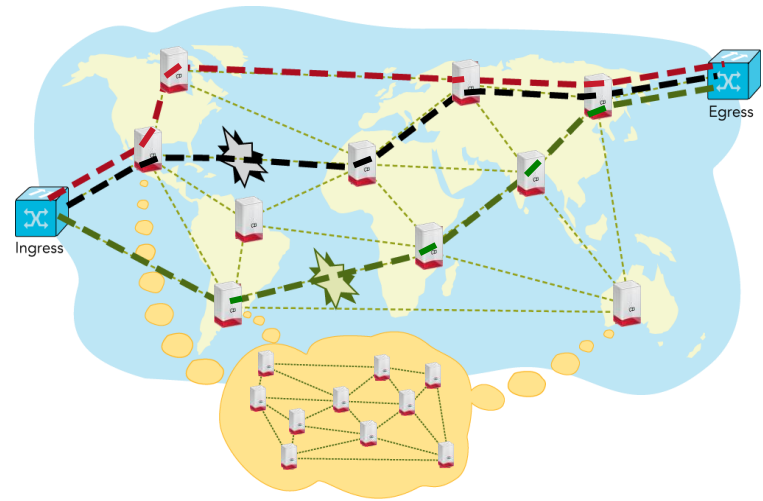
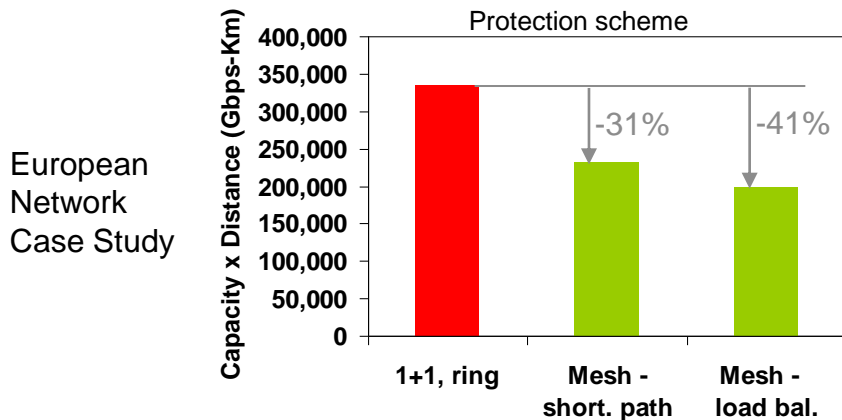

→ Proven, robust, feature-rich, scalable

→ World's largest mesh network

→ scalable to 800+ nodes

→ rich network design tools



# The Challenge: Rising Levels of IP and Ethernet Traffic

Ethernet

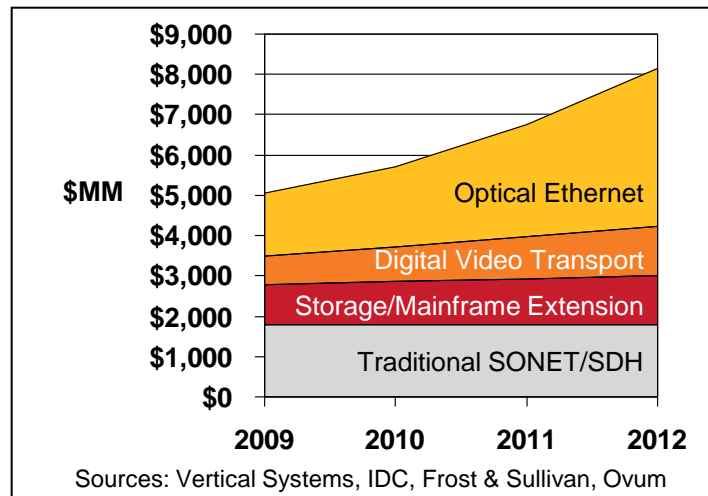
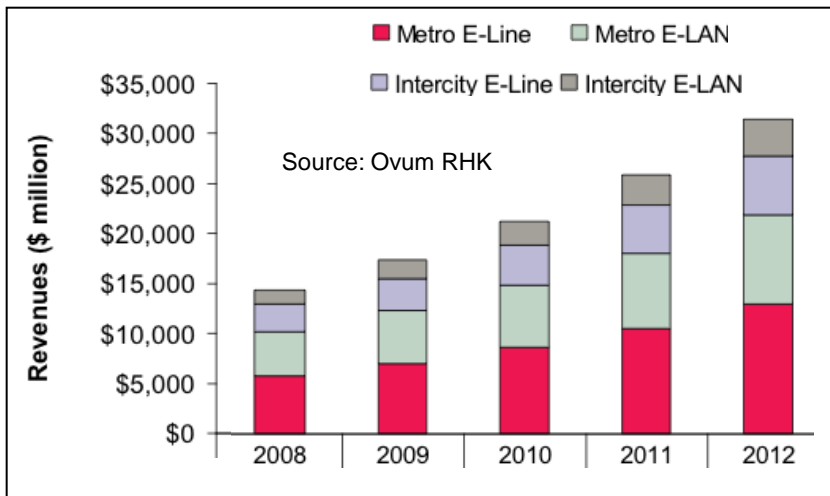

Optical

IP

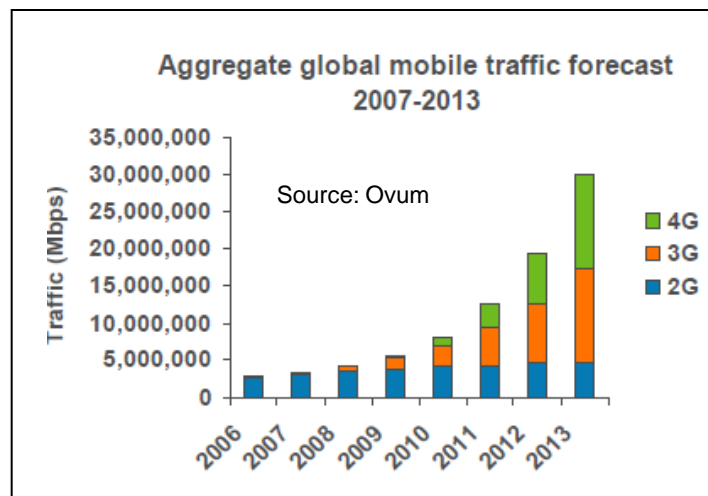
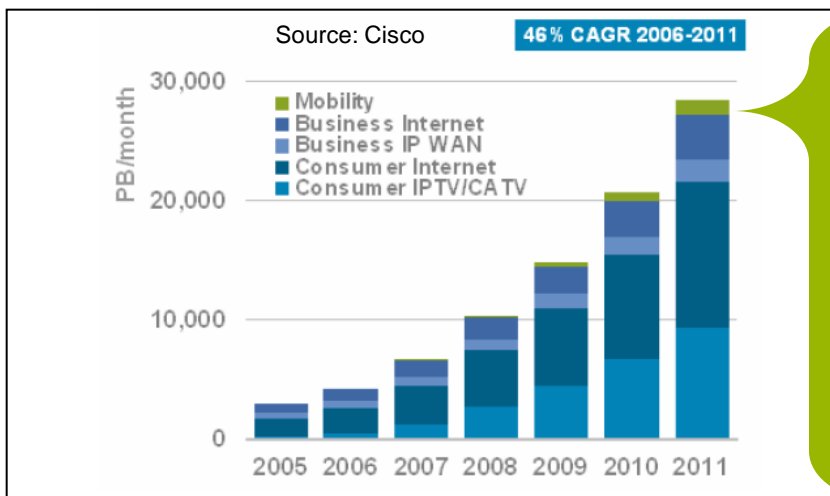

Need cost-effective and flexible transport of a variety of traffic



# Solution: Integrated Packet-Optical Networks that lower IP and Ethernet transport cost

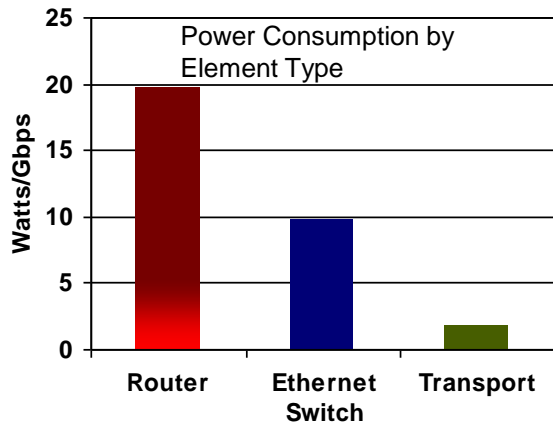
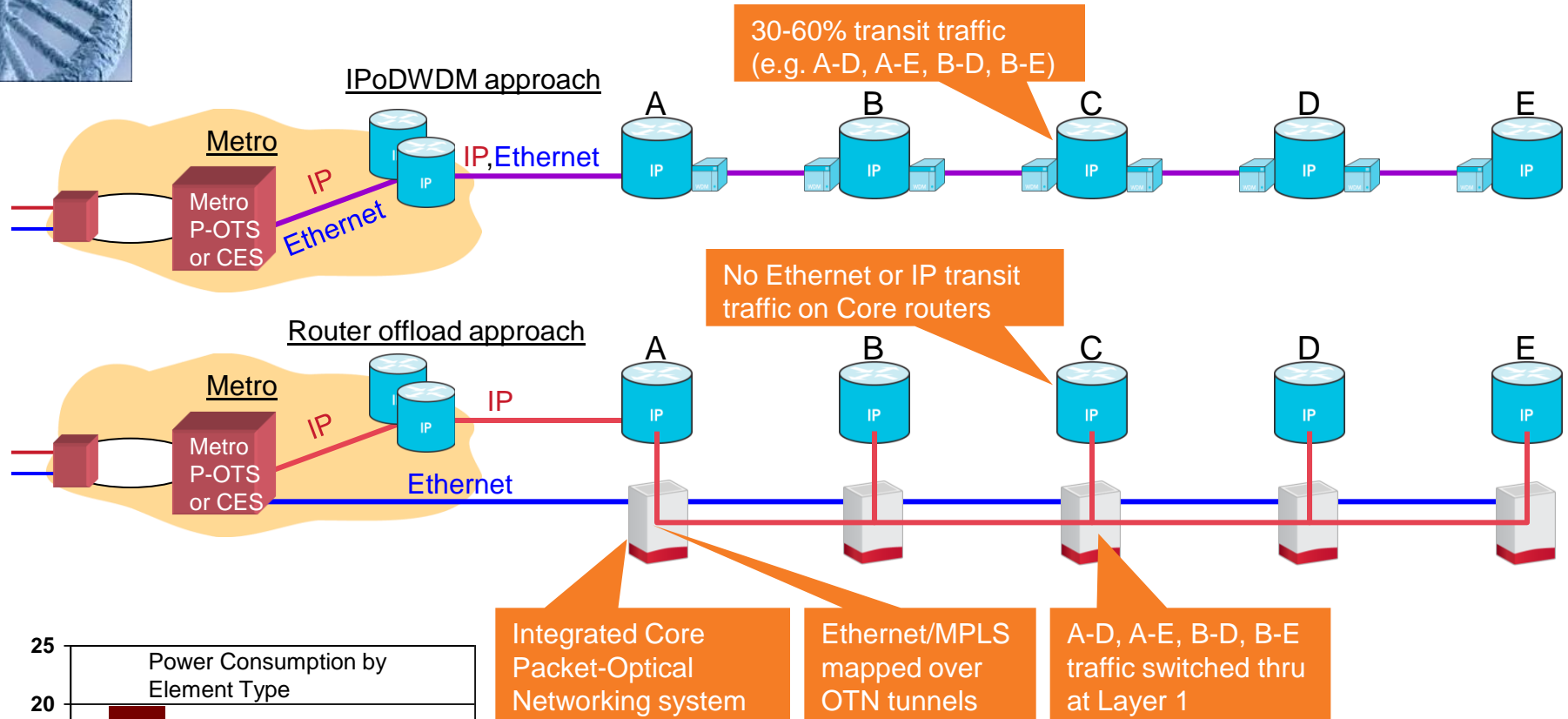

## Transit traffic handled at lower cost layers

- Via automated, mesh-restorable Layer 2/1 connections
- Fewer router ports; smaller core routers
- 35% to 60+% capex & power savings

# Ciena's Core Products: Integrated Packet/Circuit Platforms with CP Capability

## CoreDirector

Mesh-based multi-layer control plane

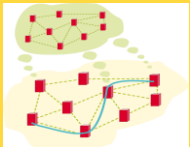

Network automation and performance optimization

- ◆ TDM core plus packet switching capability
  - ◆ 640 Gbps TDM core
  - ◆ Packet line modules
- ◆ Industry's most widely deployed intelligent control plane solution
  - ◆ Supports OIF E-NNI Control Plane Interoperability
  - ◆ Extended to support intelligent OTN connections



## 5400 Family

Mesh-based multi-layer control plane

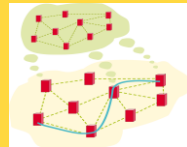

Network automation and performance optimization

- ◆ Integrated packet-TDM-optical switching
  - ◆ TDM and packet cores
  - ◆ 1.2 Tbps and 3.6 Tbps switch fabric modules
- ◆ Ciena's intelligent control plane
  - ◆ SONET/SDH and OTN
  - ◆ Future packet/optical
- ◆ 10 Tbps per fiber
  - color/directionless ROADM
  - 10/40/100G long-haul transmission



# Control Plane Interoperability and Standards

Multiple Bodies Working Different Sides of the Problem

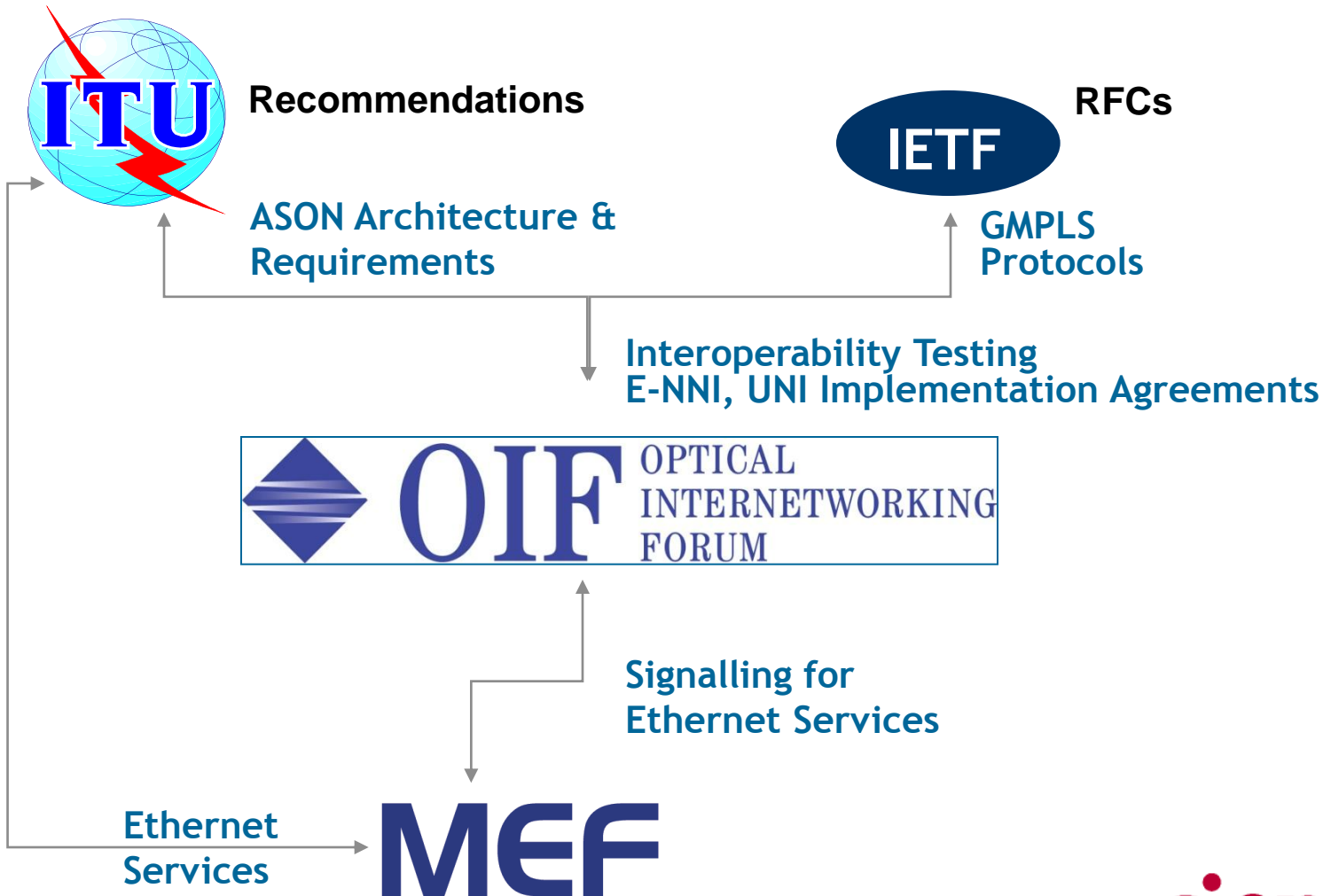

# Standards Body Activities

## ITU-T

- **Core optical transport standards, e.g., OTN, WDM**
- **Architecture for optical control plane**
- **Status:**
  - Basic functional specs completed (G.8080, G.771x series)
  - Work continuing on transport specs, esp. OTN (G.709)

## IETF

- **Core expertise in IP-based protocols, esp. RSVP and OSPF**
- **Protocol extensions to support new technologies**
- **Status:**
  - Basic control plane specs completed (RFC 3471/3, 4202/3)
  - Additional technologies in progress (PBB-TE, MPLS-TP, WSON)
  - Enhanced routing (PCE)

# OIF Control Plane Goals\*

On-demand services are provisioned, based on ASON/GMPLS control plane functions, even across heterogeneous network infrastructures

- ◆ Multi-domain
- ◆ Multi-layer
- ◆ Multi-technology

A close fit with Ciena's objectives

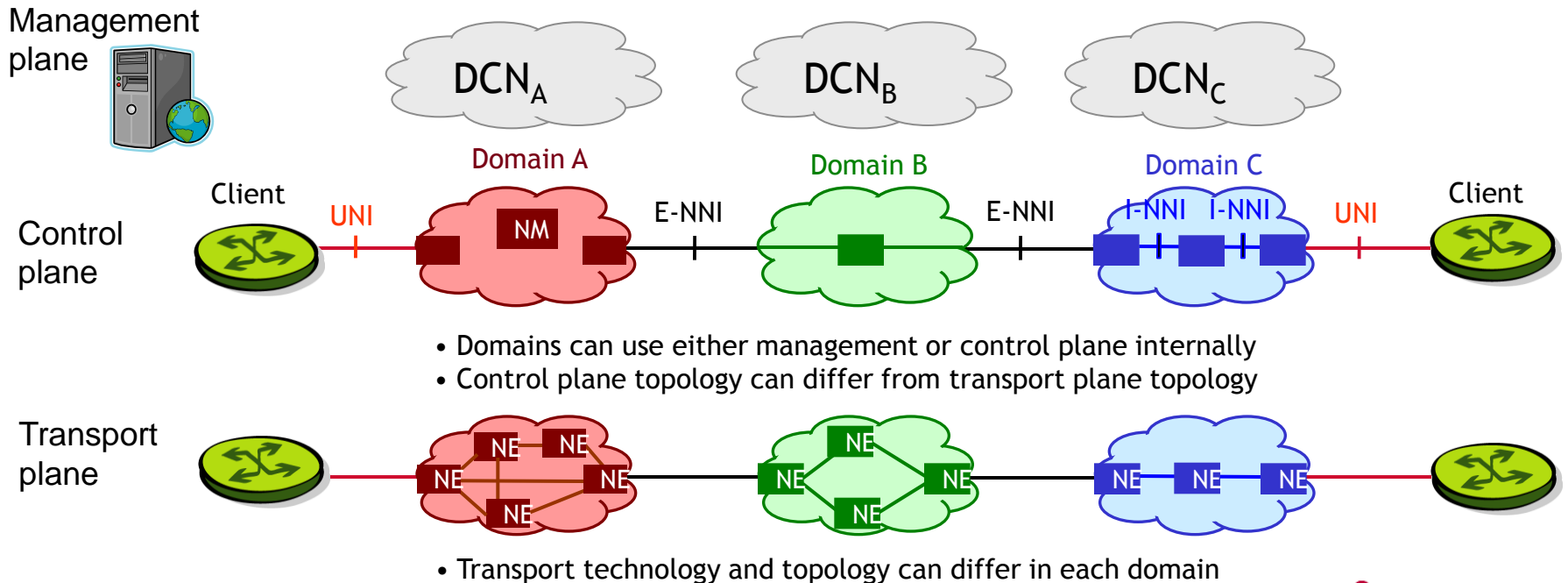

\* see [http://www.oiforum.com/public/OIF\\_Networking\\_Demo\\_2009.html](http://www.oiforum.com/public/OIF_Networking_Demo_2009.html)

# OIF Activities

*OIF Implementation Agreements and Interoperability Demos*

## OIF Implementation Agreements

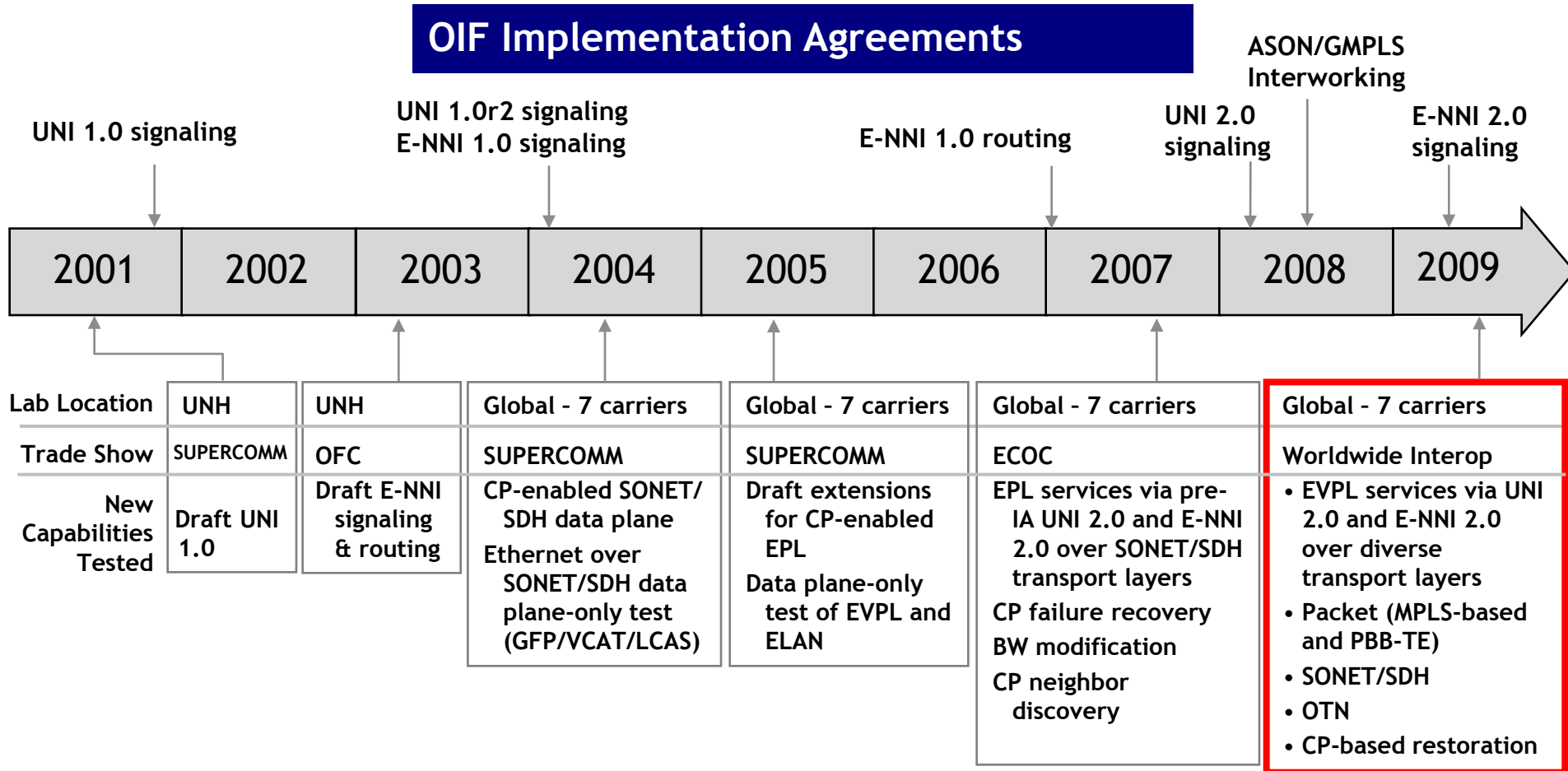

## OIF Networking Interoperability Demonstrations

# OIF Demonstration Topology

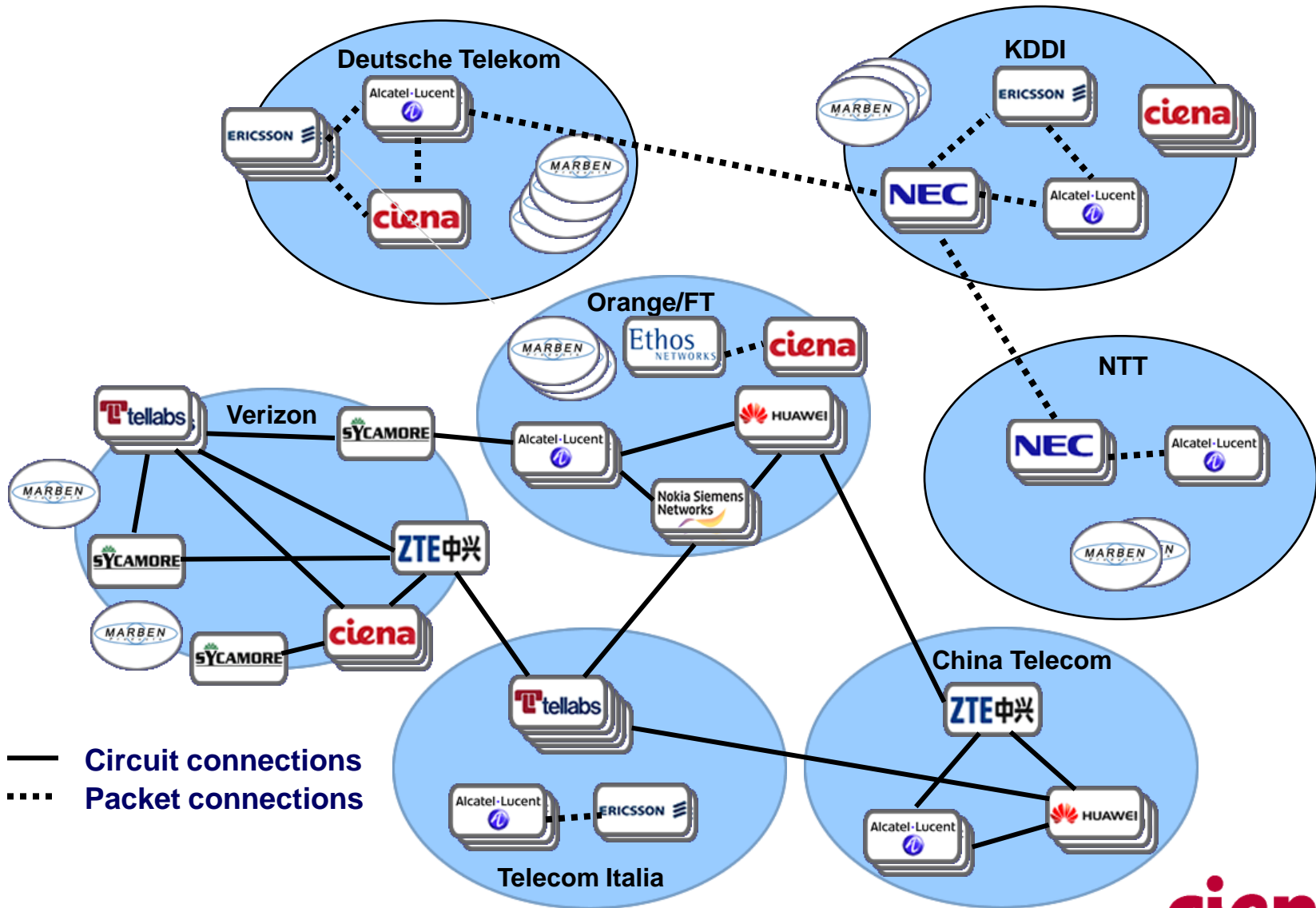

# Example Test Site at Verizon Labs

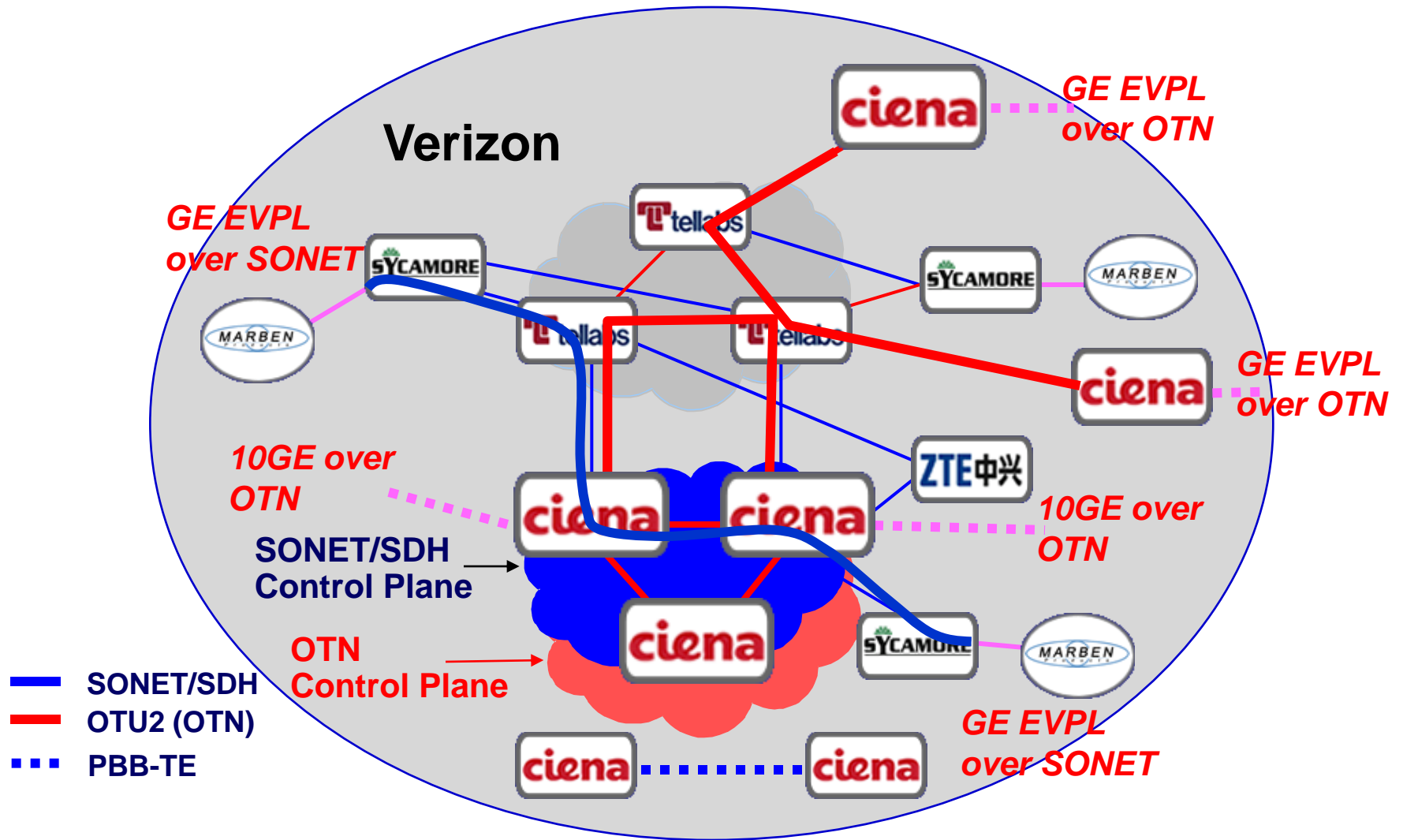

# Testing of EVPL Services Over SDH and OTN

**EVPL: Packet forwarding based on VLAN tag/group over SDH/OTN connections with desired granularity**

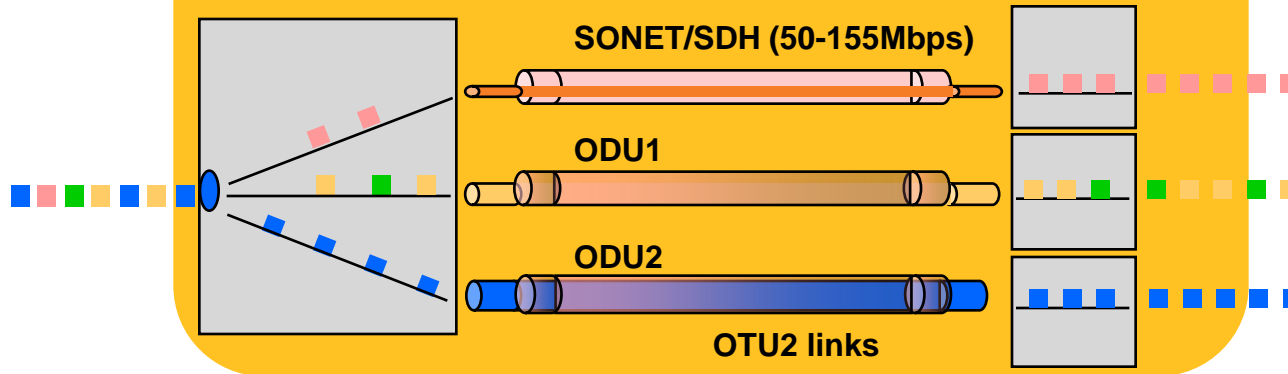

- ◆ **Common Features:**
- SONET/SDH interoperability
- OTN interoperability at ODU1/ODU2
- G.709 Ethernet to OTN Mapping
- GE/10GE Ethernet Interfaces
- Added Port and Bandwidth Efficiency

**GE & 10GE  
EPL/EVPL Services**

**Ethernet Adaptation  
to OTN**

**OTN Interoperability**



**CN 4200  
Service Transport Family**



**CoreDirector**

# Testing of EVPL over PBB-TE Transport

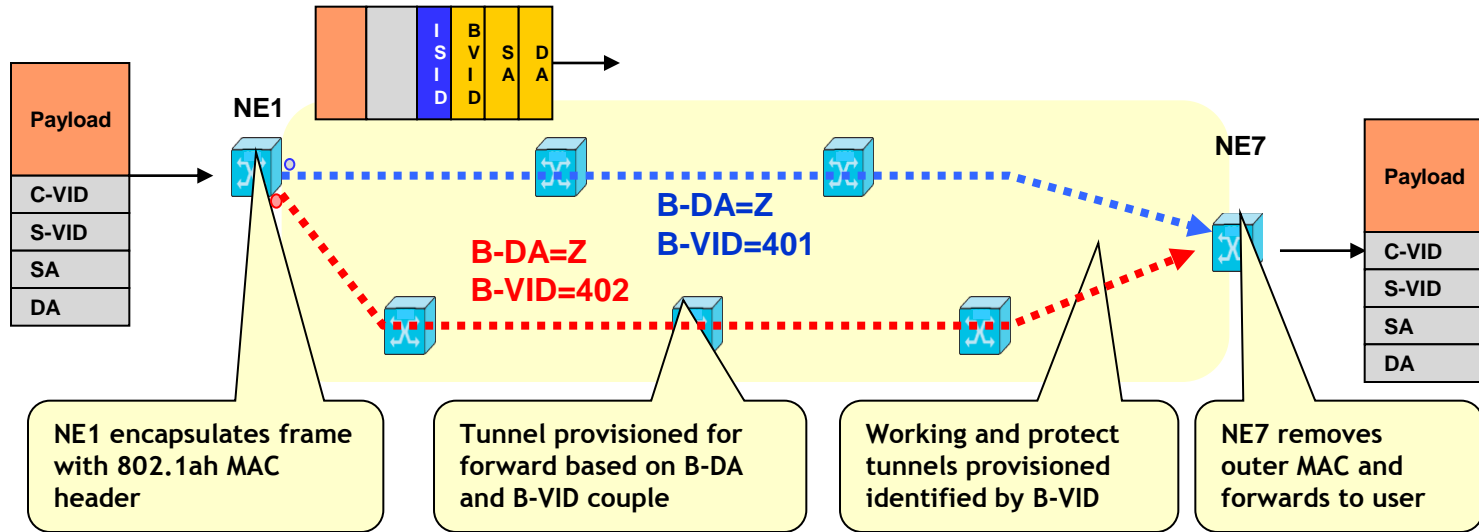

LE-311v  
Service Delivery Switch

## Carrier Ethernet Solutions:

- Scalable
- Interoperable
- Secure
- Multi-protocol



CN 5305  
Service Aggregation Switch



# Future Directions



# Two Directions of Future Work

## Application of Control Plane to Additional Transport Technologies

- OTN (Electronic signals)
- Packet (PBB-TE and MPLS-TP)
- WSON

## Control Plane Technologies

- **Additional extensions to standards for real deployment**
  - Support of networks with diverse domains and technologies
- **Supplemental Interfaces**
  - PCE
  - APIs such as OpenFlow

# Supplemental Interfaces

## PCE Concept

### → Path Computation as a separate, distinct component

→ Can be physically hosted separate from the NE, e.g., on a server

→ Requires an interface between the NE and the PCE

### → Promising approach for more difficult networking problems

→ Complex computation, or incomplete information

→ Applies well to photonic routing including optical impairments

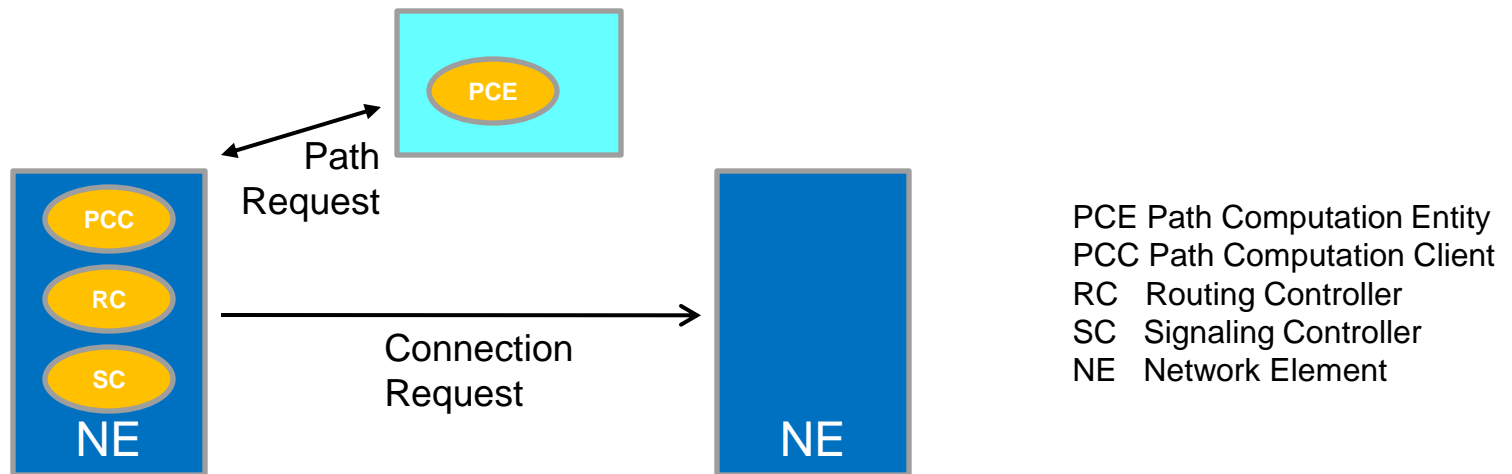

# Unified API: Ciena/Stanford OpenFlow Demo

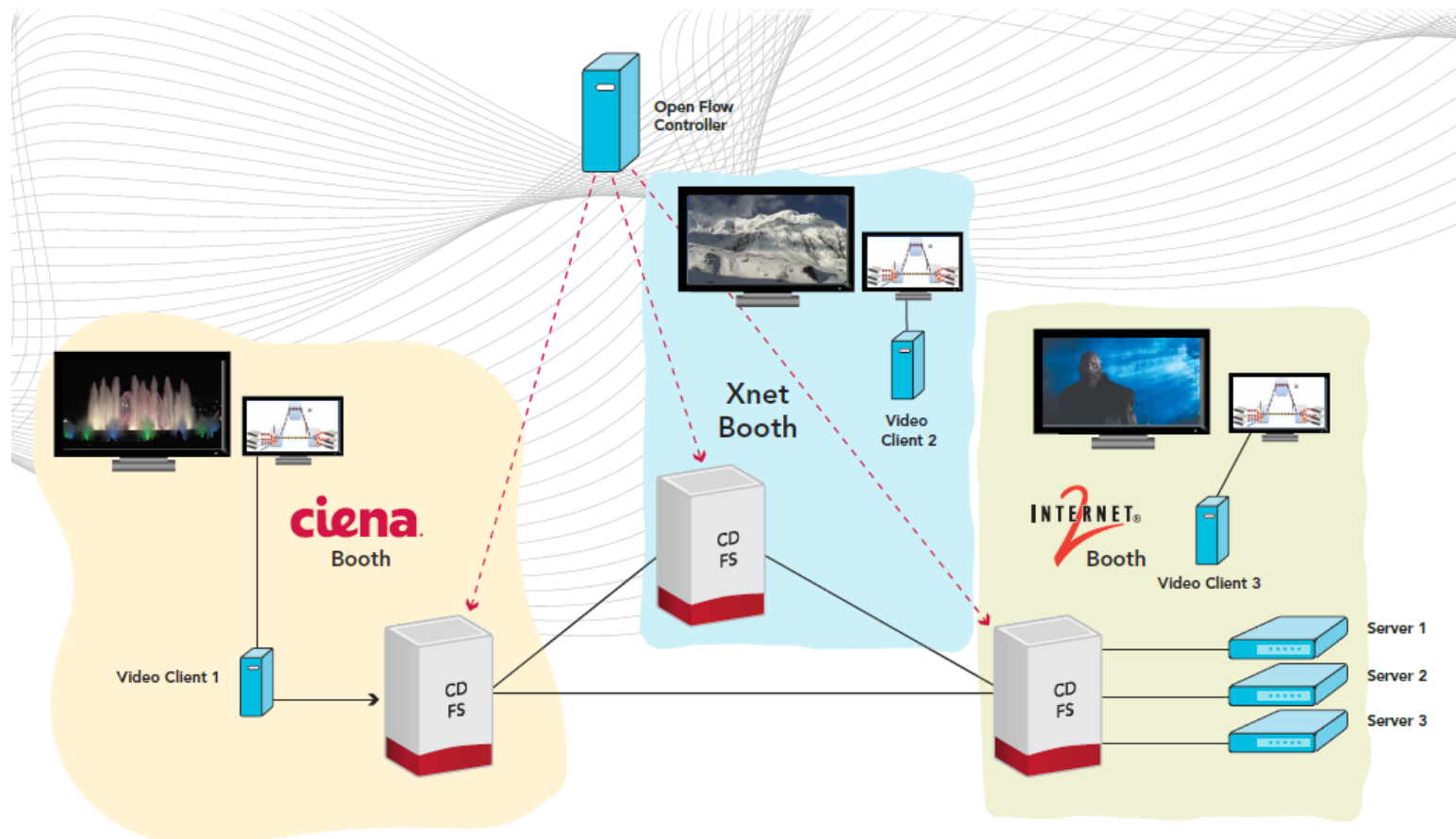

**CoreDirector integrated packet/optical switching capabilities**

**OpenFlow Controller with integrated packet and circuit control**

**Demonstration video streaming transport application – L1 and L2 path control**

# Summary

**Optical Control Plane has been successfully deployed**

- **Capex and Opex savings shown, some BoD services deployed**
- **Deployed more on savings than new services**
  - Subject to issues with carriers' operational environment

## **Future Challenges**

- **IP, Ethernet and Optical services and traffic are growing**
- **Core networks need to be modernized to more economically handle a mix of packet and TDM traffic**
- **Ciena believes this is best addressed by**
  - Integration of Packet Transport, SONET/SDH, OTN and photonic switching capabilities in the data plane and
  - Use of control plane technology to help automate inventory, provisioning and recovery, while enabling new services